

# z/VM – KVM – Red Hat OpenShift Virtualization Hypervisor Choices for IBM Z and LinuxONE

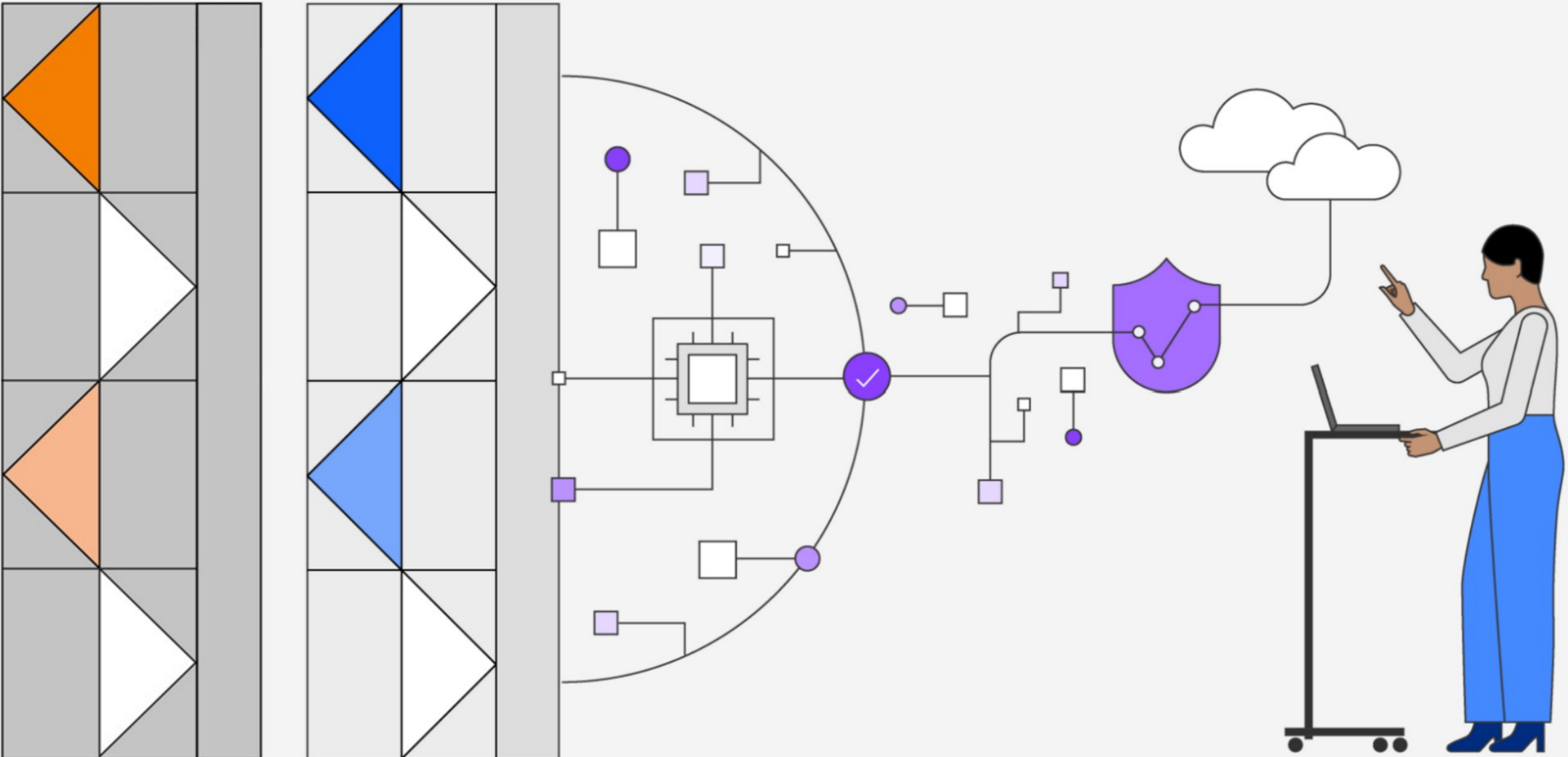

Dr. Ulrich Weigand  
Distinguished Engineer  
IBM Z Hypervisors and Compilers  
[ulrich.weigand@de.ibm.com](mailto:ulrich.weigand@de.ibm.com)



# Agenda

- Workload Deployment Options
- Virtualization Development Focus Areas
- Hypervisor Choice

# Workload Deployment Options

# Application Deployment Options on IBM Z

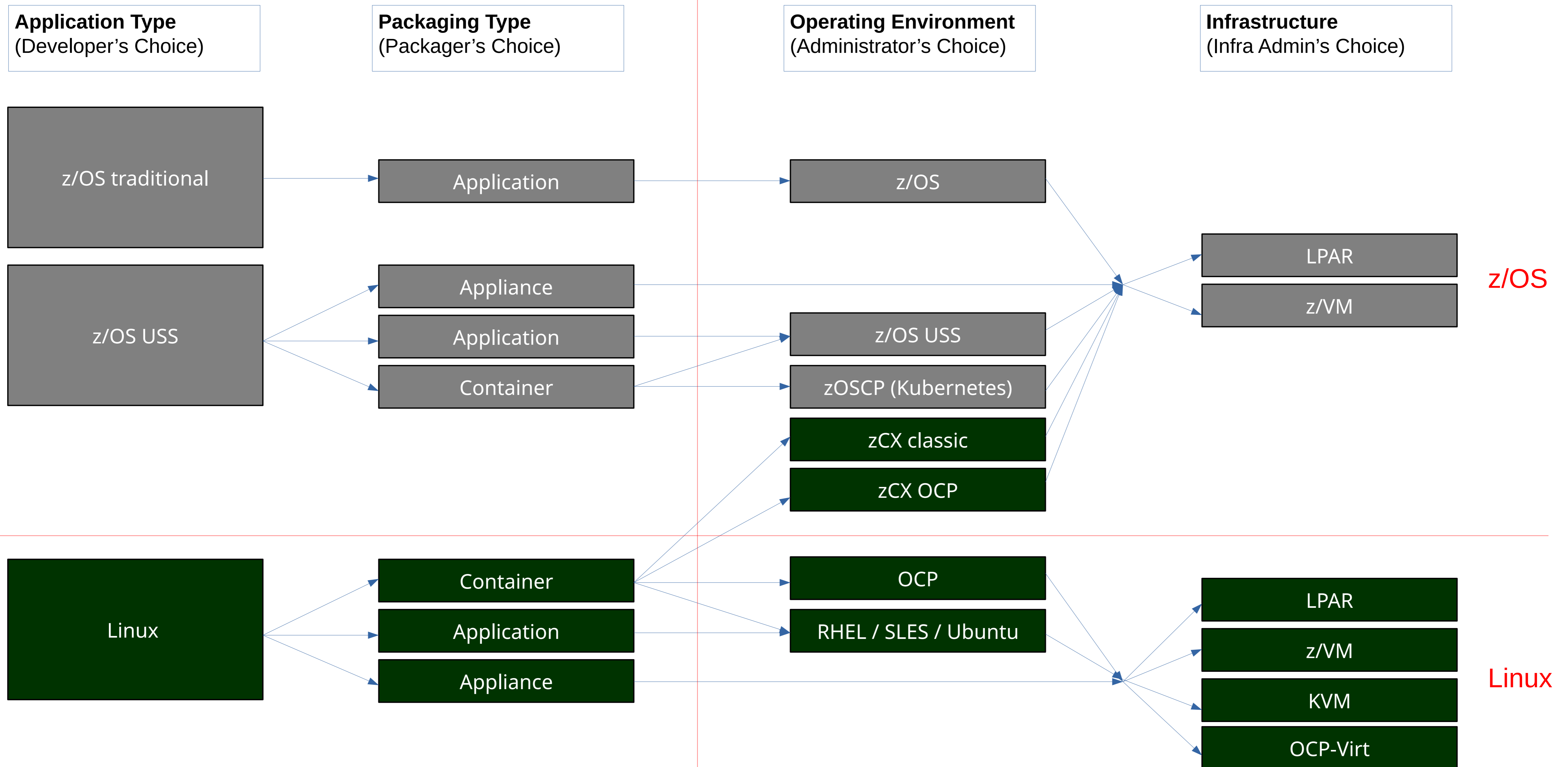

# Virtualization on IBM LinuxONE and IBM Z

## *Built-in & Shared Everything Architecture*

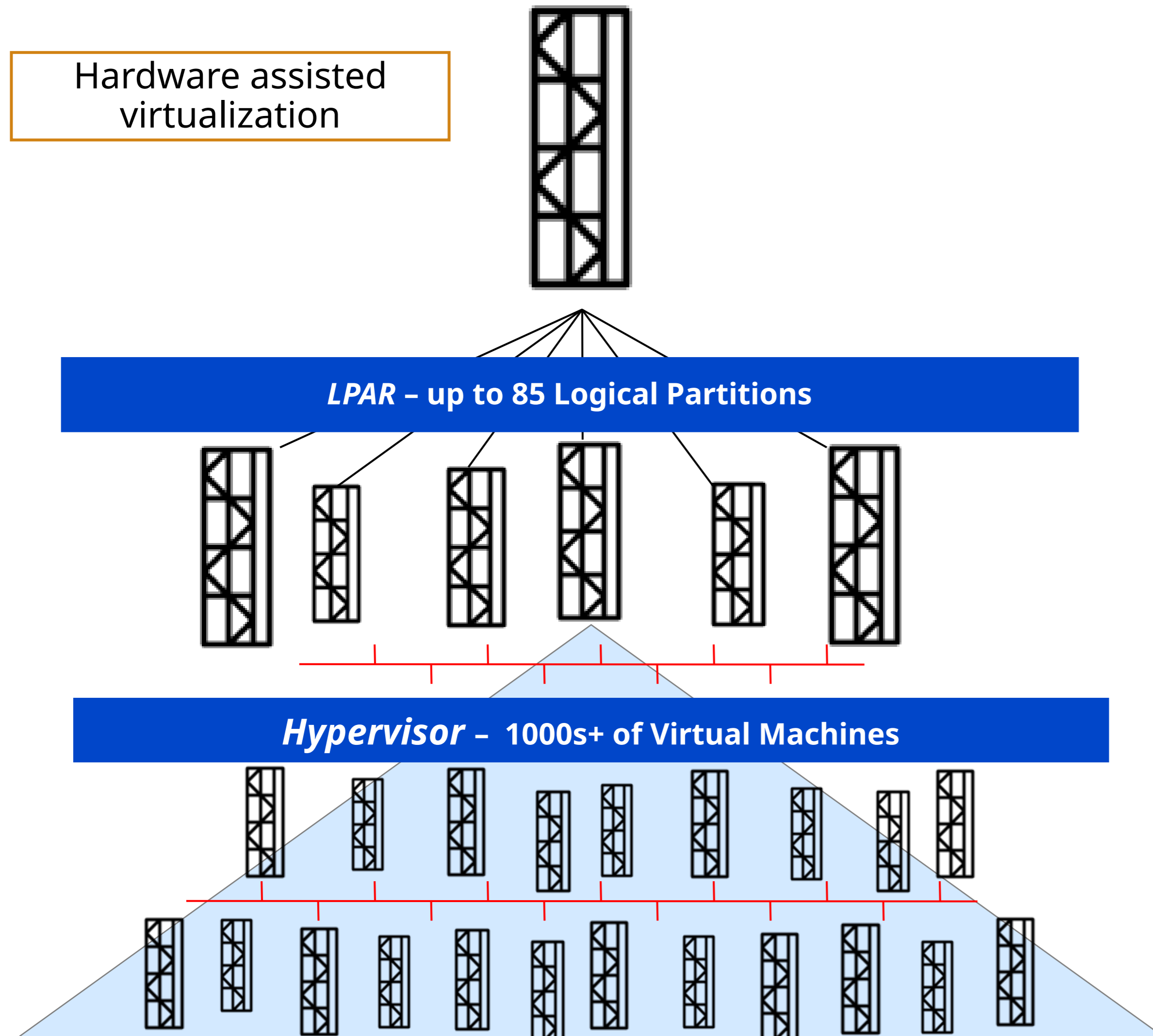

- Consolidate to gain efficiencies by virtualization
- Focus on virtual server resource management
- Few applications per VM / OS instance
- Provides application and operating system isolation
- Higher utilization of resources

# Virtualization Platform

Modernize for efficiency and hybrid cloud.



**Maximize data center usage with efficiency and security, providing cost savings and the foundation for cloud computing.**

Modernize workloads and integrate management into your hybrid cloud

Apply **Zero Trust policies** with attestation for compliance and auditing

**Live relocation** for high flexibility of virtual servers

Run **thousands of workloads** on a single server

## Cloud computing

Manage lifecycle of virtual infrastructure and integrate with enterprise hybrid cloud mgmt.

## Confidential computing

Isolated application execution inside a Trusted Execution Environment (TEE)

## Continuous availability

Software & hardware maintenance/upgrades without disruption to the business

## Cost-effectiveness

Less cost for software licenses, operational efforts, security investment, energy, floor space, maintenance, etc.

## Technologies

- IBM z/VM®
- Red Hat® OpenShift® Virtualization
- Red Hat Enterprise Linux (RHEL) KVM
- SUSE Linux Enterprise Server KVM
- Canonical Ubuntu Server KVM
- IBM Cloud Infrastructure Center

# Linux Workload Placement Overview

- **LPAR**: static deployment models, highest performance, appliance use (e.g. IDAA)
- **z/VM**: mature hypervisor, Oracle consolidation & other data-serving workloads, hosting non-Linux guests
- **Linux with KVM**: Confidential Computing, Linux admin skill set, technology base for OpenShift Virtualization & open-source innovation
- **z/OS with zCX**: tightest integration of container workloads with z/OS, no Linux admin skill required

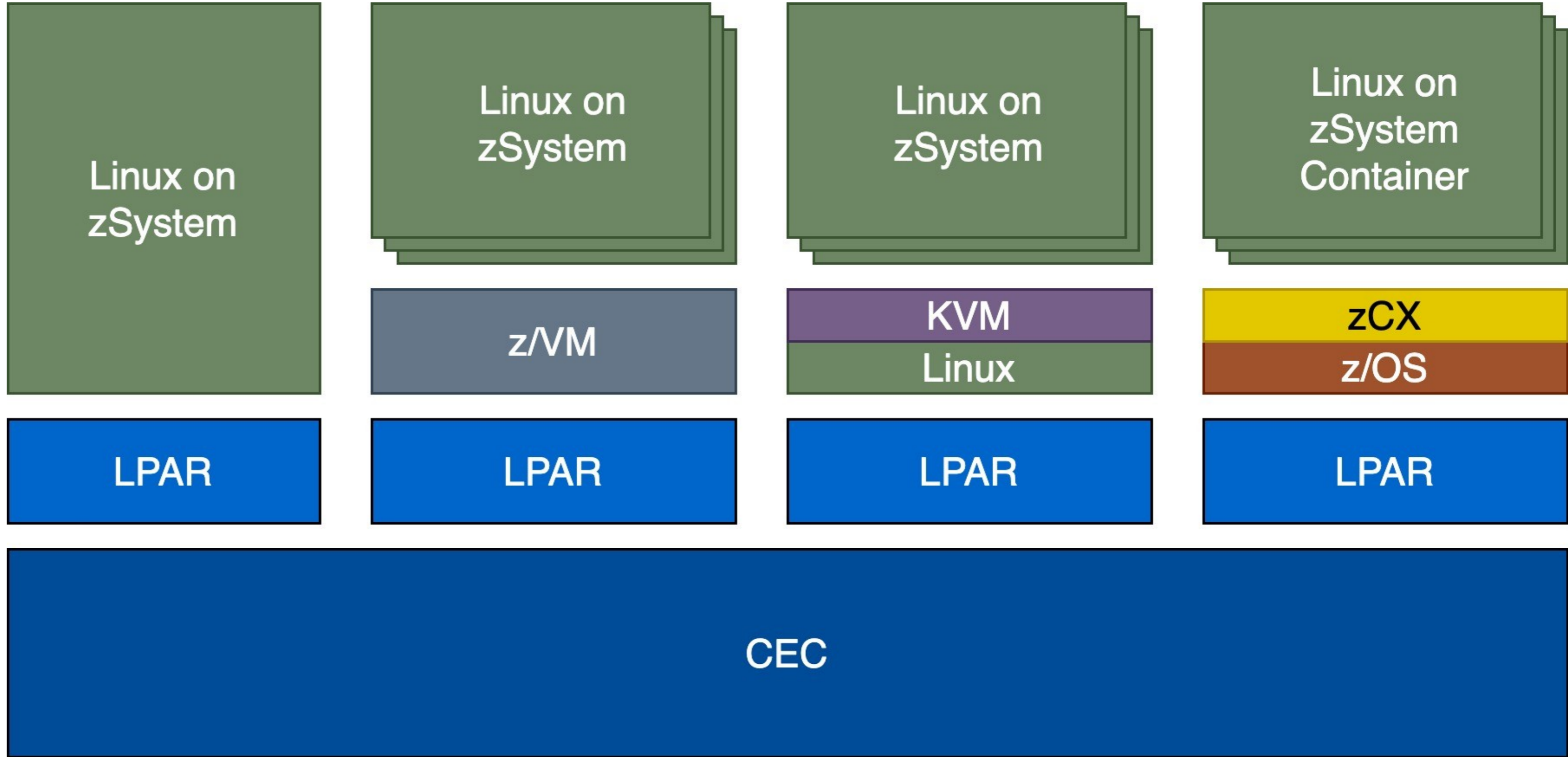

# KVM Components

Host resource management  
Virtual server life cycle

---



I/O virtualization  
CPU and memory support

---



CPU and memory



# KVM Management Infrastructure

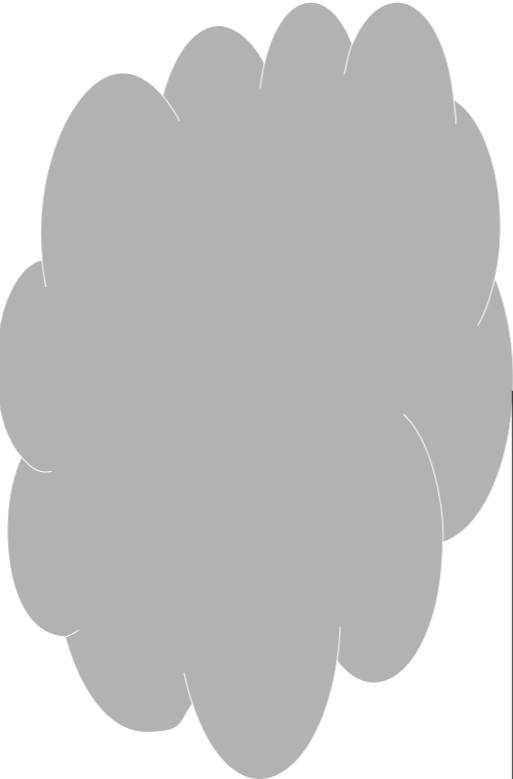
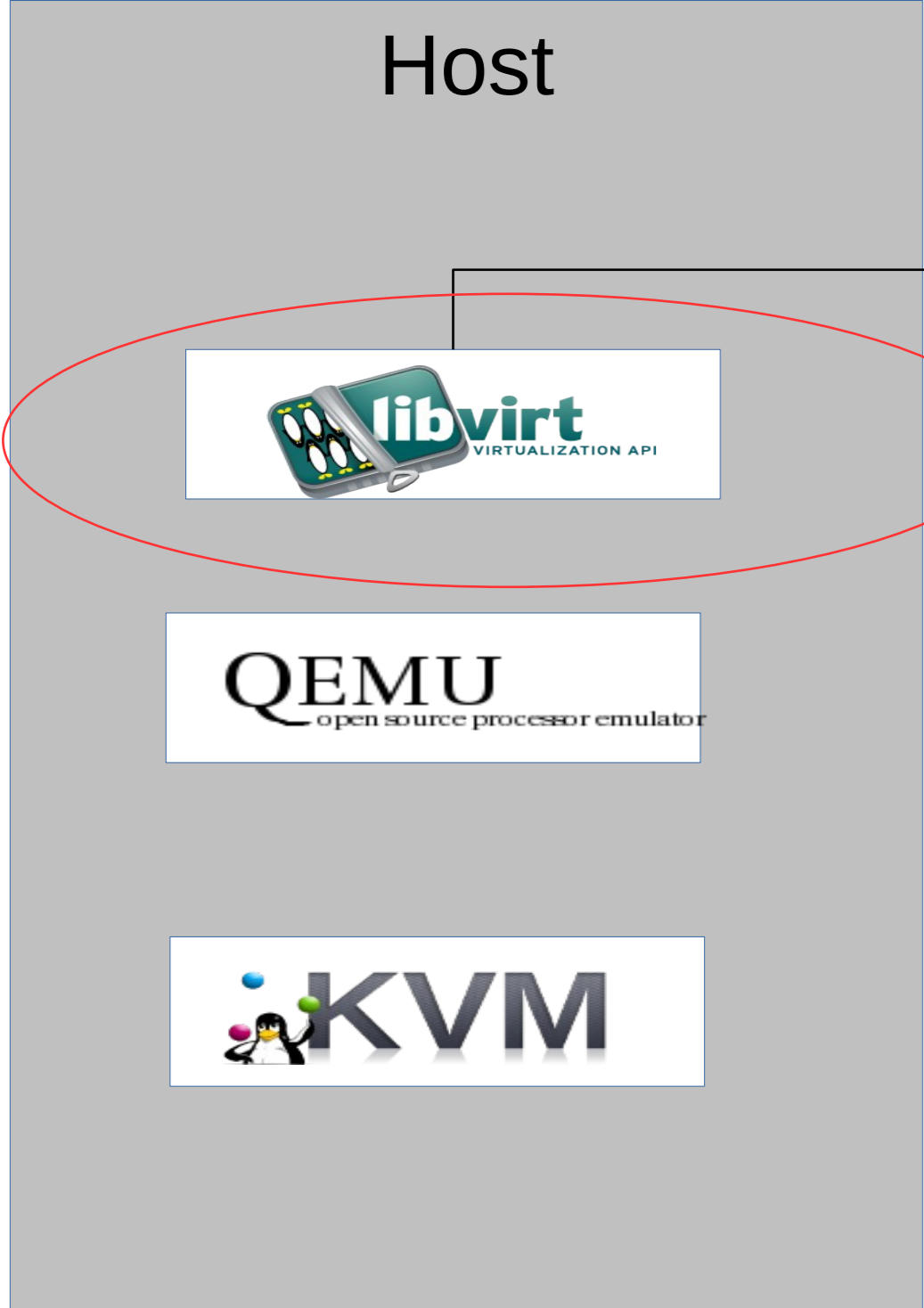

virsh

```
File Edit View Terminal Help
virsh # list --all
-----
Id Name                               State
-----
2  extern                               running
- host                               shut off

virsh #
```

Virt Manager

Name	CPU usage	Host CPU usage	Memory usage	Disk I/O	Network I/O
QEMUKVM: 9:12:22:44					
u20evp	Running				
RHELGUI	Shutoff				
ocp7wk4	Running				
ocp7wk3	Running				
ocp7wk2	Running				
ocp7wk1	Running				
ocp7mst1	Running				
ocp7hap1	Running				
ocp7dns1	Running				
ocp7cp3	Running				

IBM Cloud Infrastructure Center (ICIC)

Host: kvm21

Host Info

- Name: kvm21
- Hostname or IP address: kvmsv21.icic.boe
- State: up
- Health: OK
- Host group membership: hostgroup1
- Disk Used (GB): 112
- Disk Available (GB): 906
- Hypervisor hostname: kvmsv21.icic.boe
- Hypervisor type: KVM
- IBM Cloud Infrastructure Center driver version: 1.1.3.0
- Shared storage path:

Processors: 2.8% (Using 9 of 320)

Memory (GB): 7.1% (Using 36 of 503.38)

OpenStack

OpenStack dashboard showing the 'Instances & Volumes' page. A message indicates: "Success: Instance 'test' launched." The 'Instances' table shows one instance named 'test' with 512MB RAM and 1 vCPU.

Name	IP Address	Size	Status	Task	Power State	Actions
test		512MB RAM   1 vCPU   0 Disk	Build	None	No State	Launch Instance, Terminate Instance, Edit Instance

Cockpit

Cockpit interface showing a list of virtual machines under the 'Virtual Machines' section. The table lists VMs with their names, connections, and states.

Name	Connection	State	Actions
ocp7bs1	System	Shut off	Run
ocp7cp1	System	Running	Shut down
ocp7cp2	System	Running	Pause
ocp7cp3	System	Running	Shut down, Force shut down
ocp7dns1	System	Running	Send non-maskable interrupt
ocp7hap1	System	Running	Reboot
ocp7mst1	System	Running	Force reboot
ocp7wk1	System	Running	Migrate
ocp7wk2	System	Running	Delete
ocp7wk3	System	Running	Shut down

# KubeVirt – Converged Management

## Virtualization

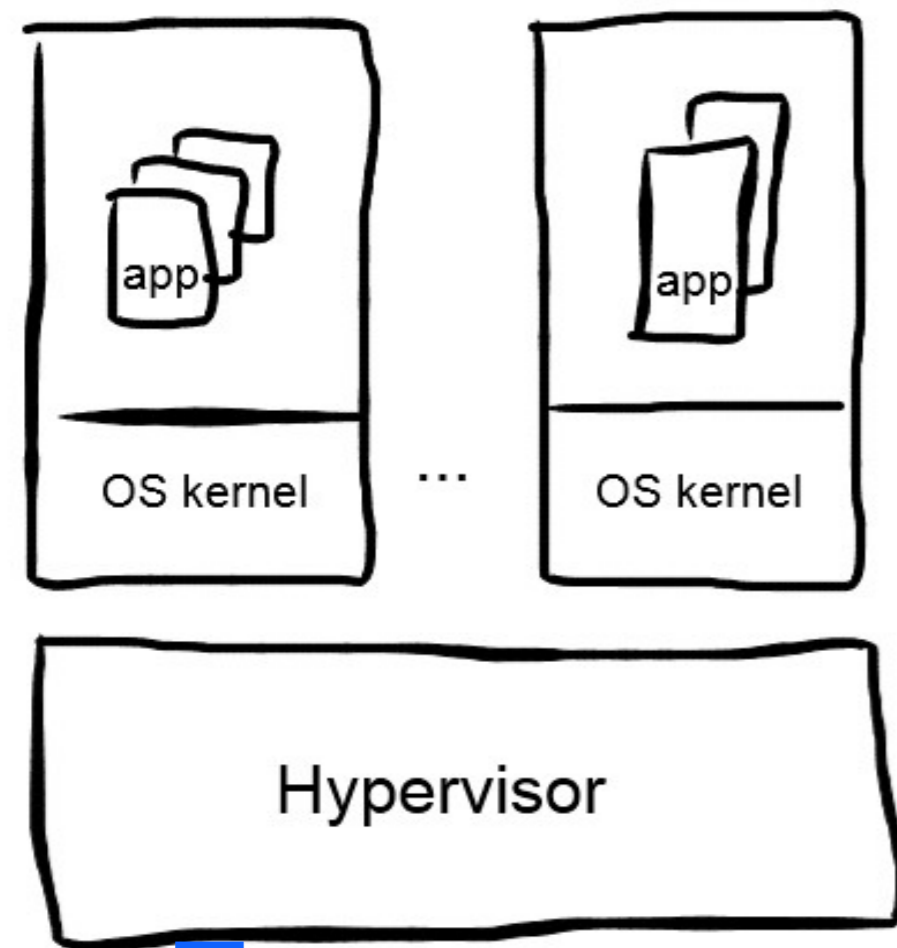

## Containerization

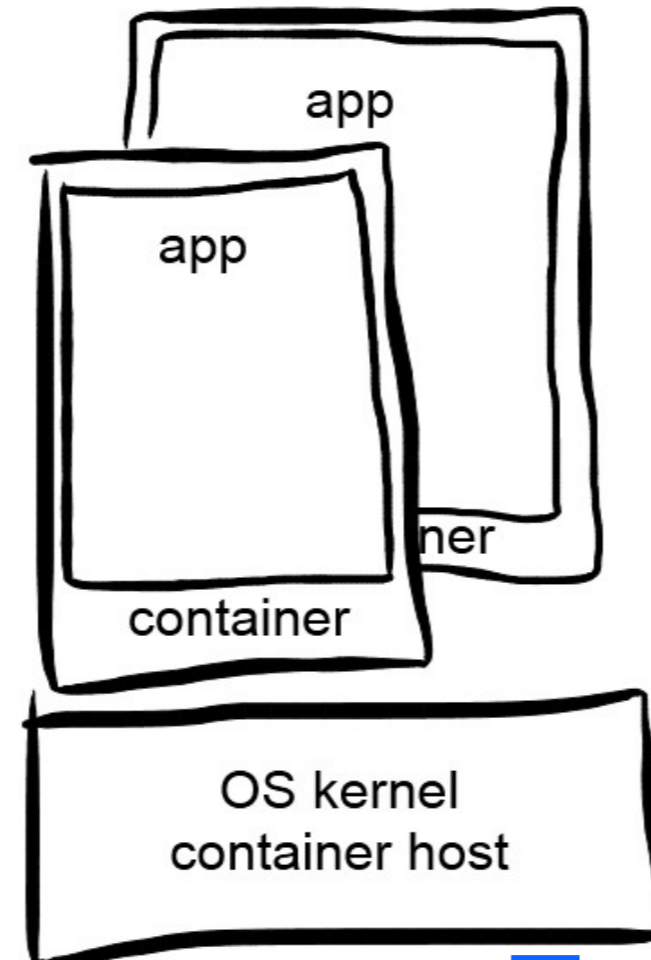

**KubeVirt**

It's not either – or –  
it's **BOTH!!**

- Deploy, run and manage containers and VMs side-by-side
- Avoid silos between traditional and cloud-native applications
- Provides opportunity to *gradually* convert traditional virtualized apps to cloud-native instead of risky mass migrations
- Single platform and single set of tools to manage hybrid applications in a consistent, efficient, secure, and compliant manner

# Red Hat OpenShift Virtualization – Background

- **Red Hat’s strategic virtualization solution**
  - Replacement for Red Hat Enterprise Virtualization (RHEV)
  - Available as (no-cost) add-on operator to be installed on an OpenShift cluster
  - Based on KubeVirt open-source project
  - Using proven KVM open-source hypervisor technology
  - Industry-standard platform integrating VMs and containers
  - Supported on IBM Z and LinuxONE since version 4.19 (Aug 12<sup>th</sup>, 2025)
- **Manage containers and virtual machines through a single pane of glass**
  - Tap into OpenShift skills broadly available in the market to administer VMs and containers
  - Accelerate application delivery with a single platform that manages VMs and containers with the same tools and in the same team
  - Modernize legacy applications over time, or continue maintaining them as VMs
- **Use cases on IBM Z**
  - Integrated management platform for VMs and containers now also on IBM Z
  - Hypervisor with industry-standard operational environment – less need for specialized skills
  - Leverage unique KVM capabilities like IBM Secure Execution within an integrated platform
  - Support multiple architectures within a single OpenShift multi-arch cluster

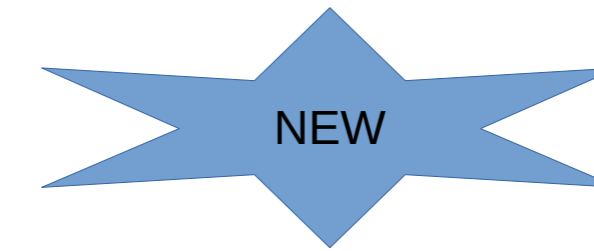

# Red Hat OpenShift

Containers running in pods

**Red Hat OpenShift Container Platform**  
Add-ons / Storage / Operators / ...

**Infrastructure**

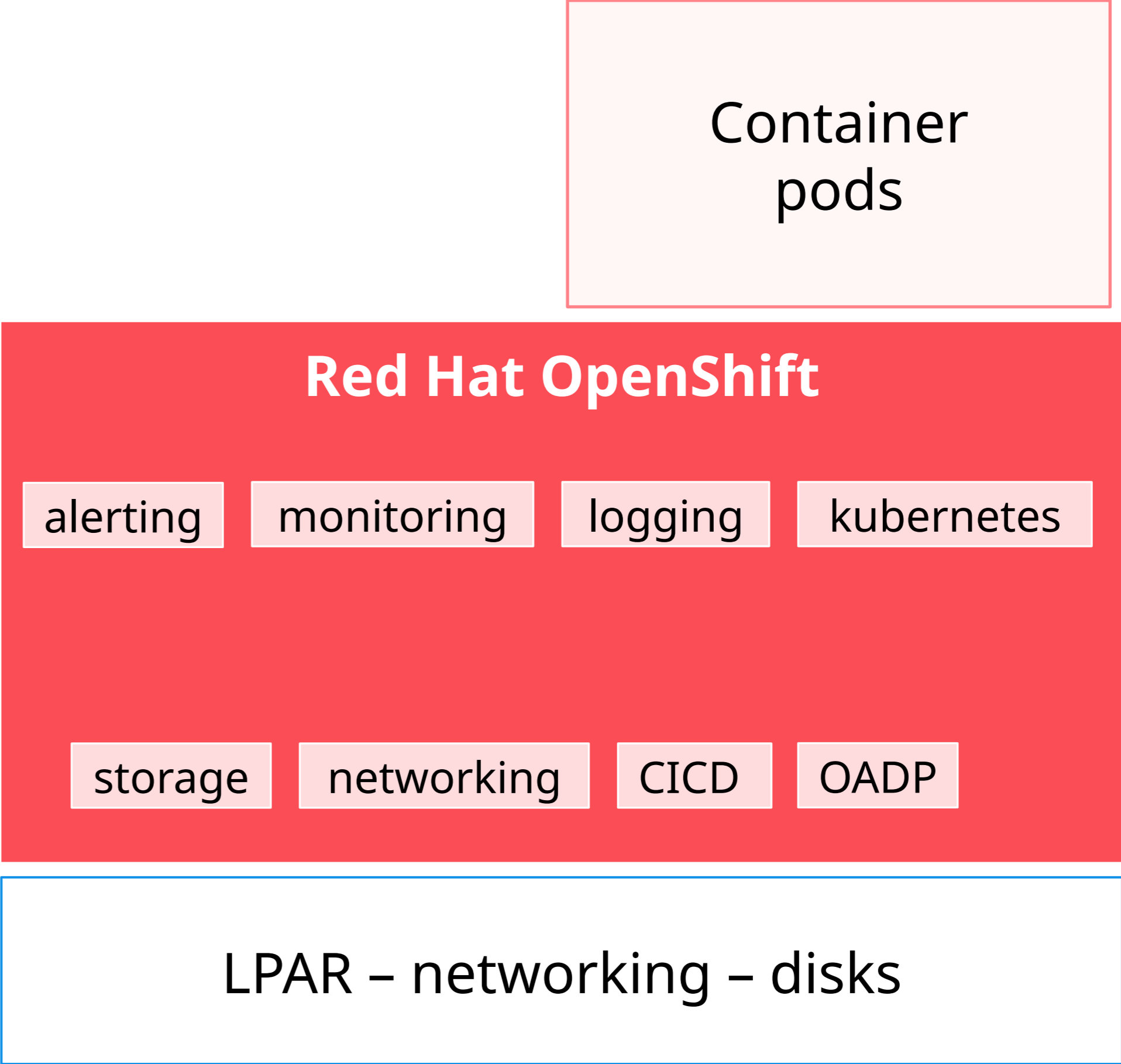

# Red Hat OpenShift Virtualization

### VMs and containers run in pods

Pods exist side-by-side and have the same access to the resources provided by the Red Hat OpenShift platform

### Red Hat OpenShift Container Platform

Add-ons / Storage / Operators – including OpenShift Virtualization Operator / ...

### Infrastructure

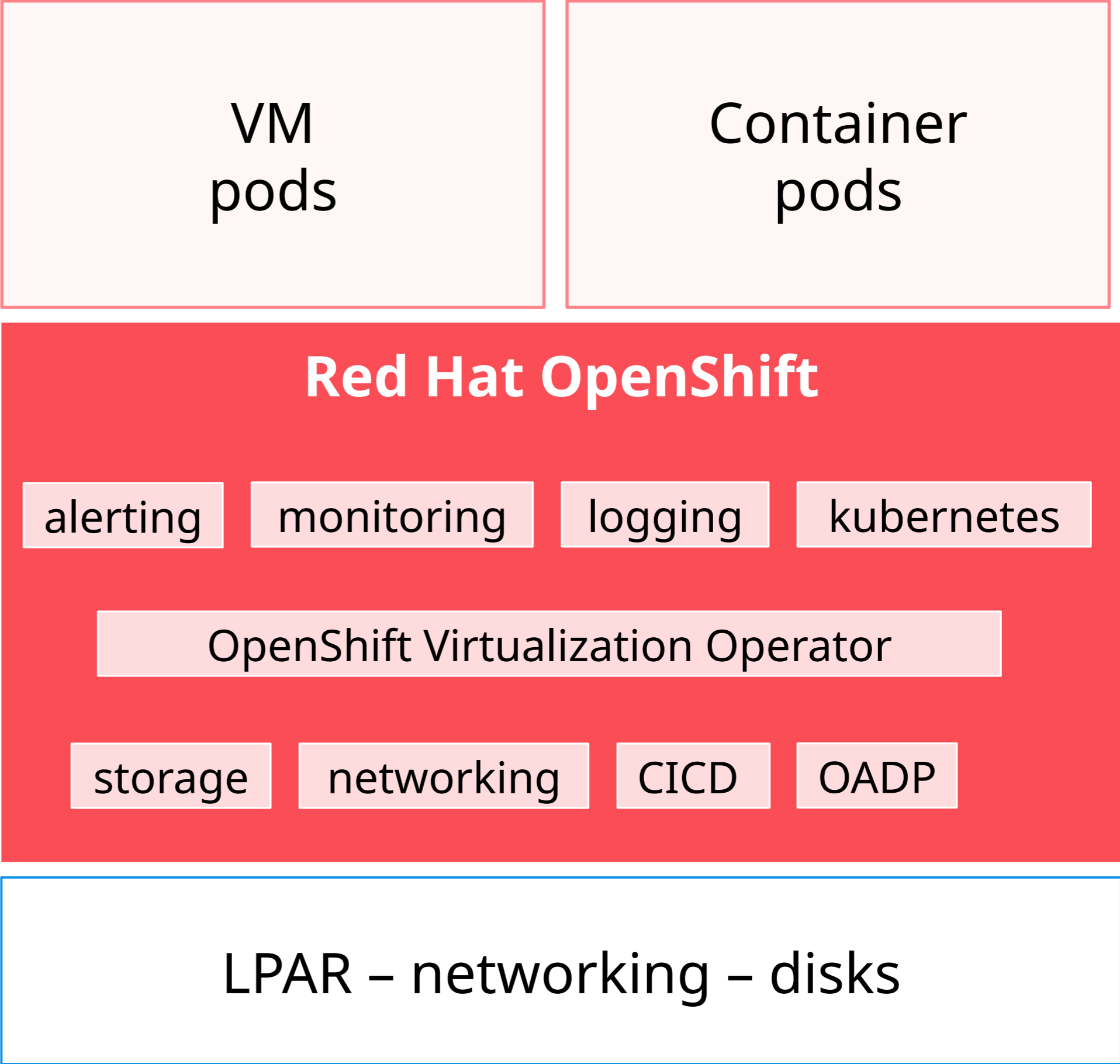

# Red Hat OpenShift Virtualization - Architecture

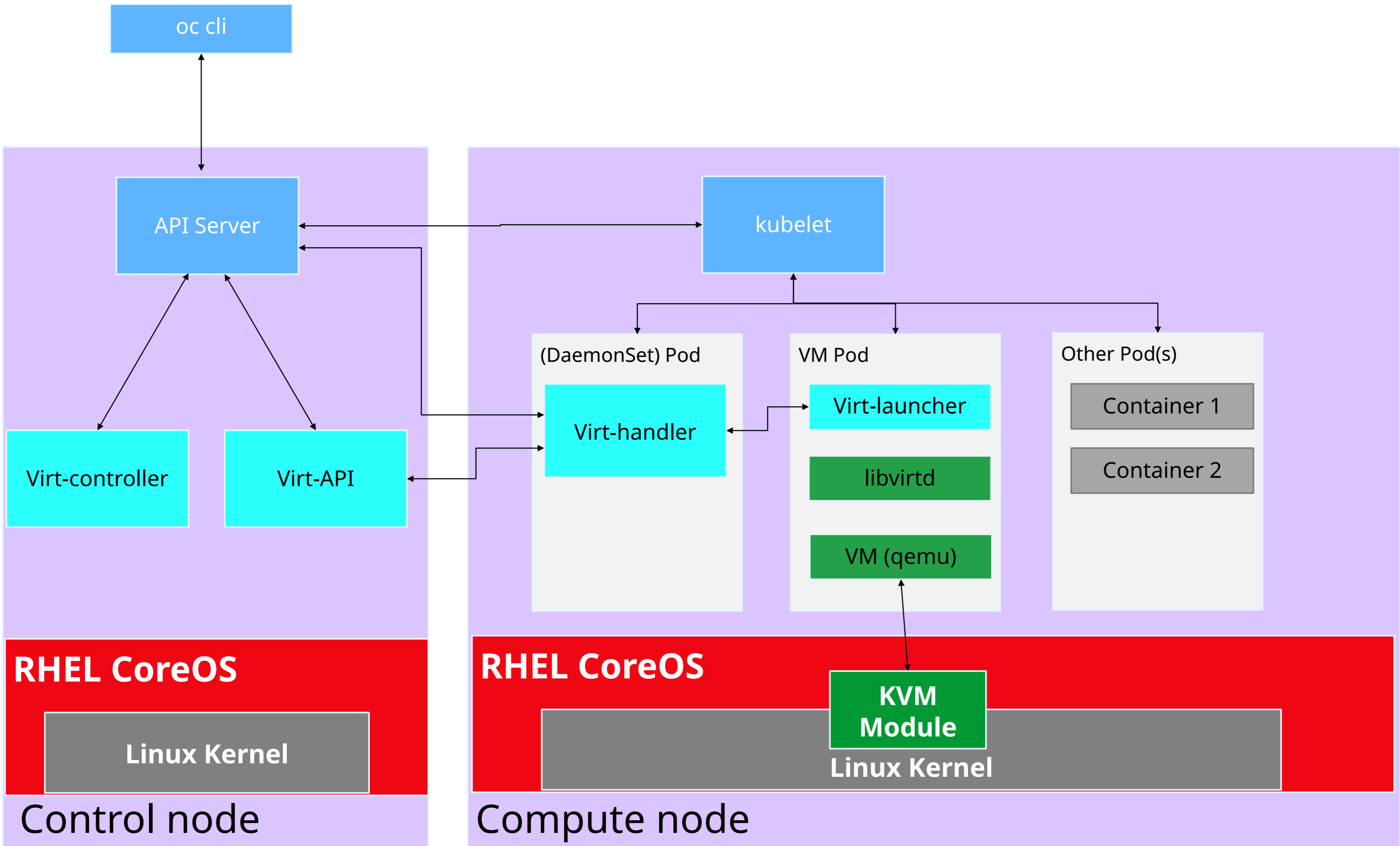

# OpenShift Virtualization

- OpenShift Virtualization - **requires** OpenShift on LPAR(s) cluster
- Existing OpenShift Cluster on LPAR(s) can be used when upgraded to **4.21**

## Installation Options

### Single node OpenShift (SNO) cluster

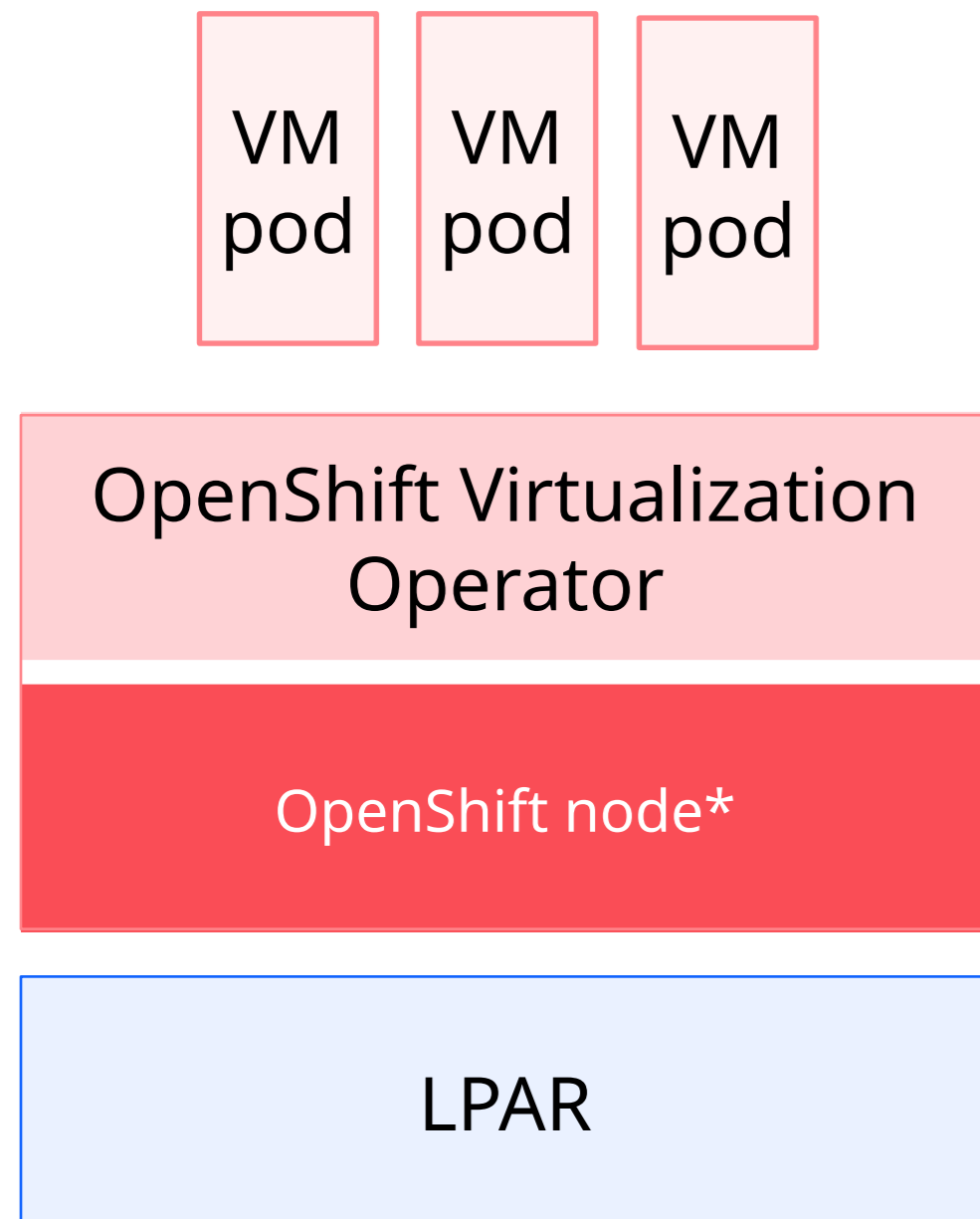

- Good for:
- Quick Start
  - POCs
  - Learning

### 3 nodes OpenShift cluster

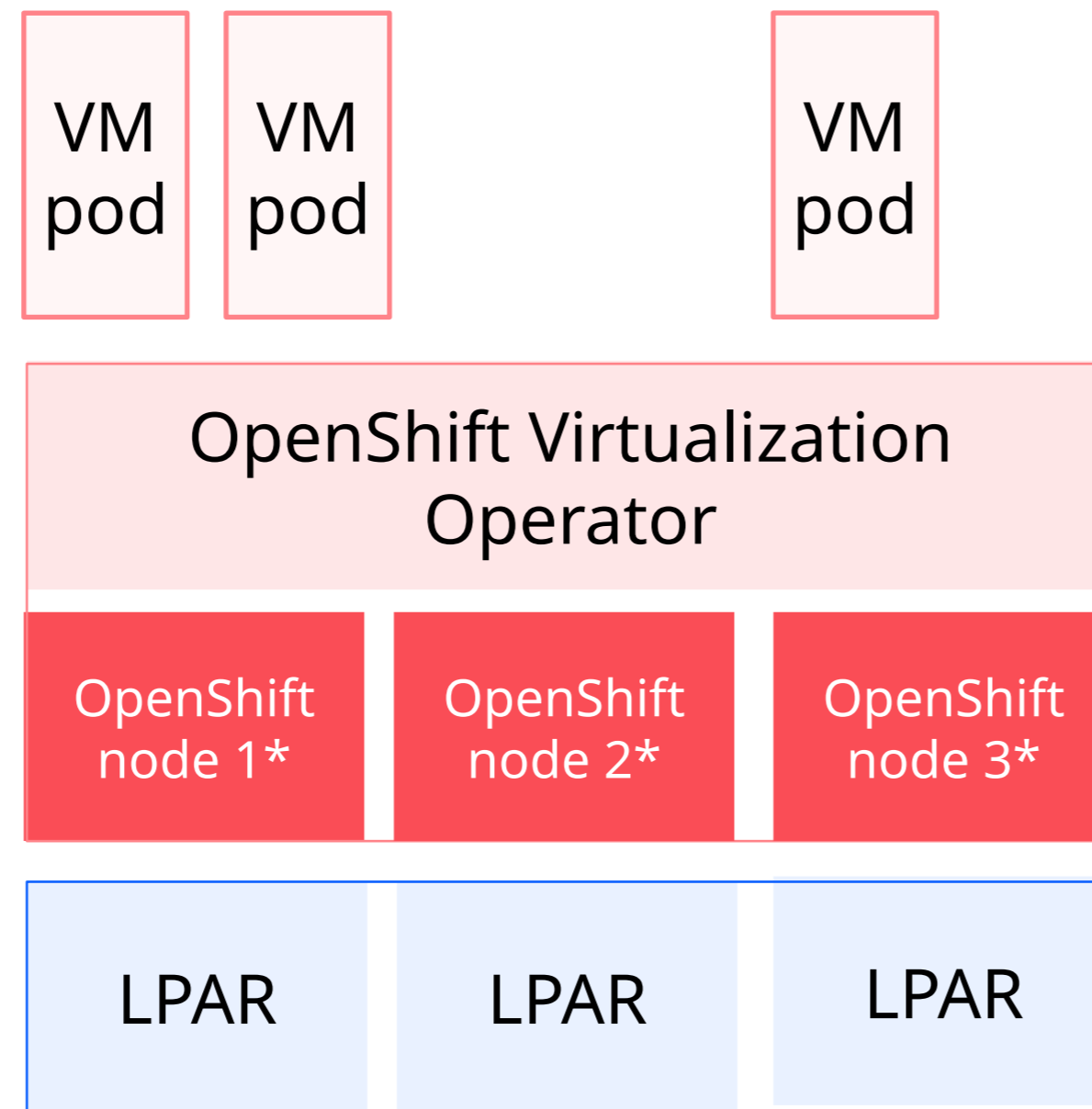

- Good for:
- High Availability
  - Scalability
  - Live Guest Migration\*\*

### 'Classic' OpenShift cluster

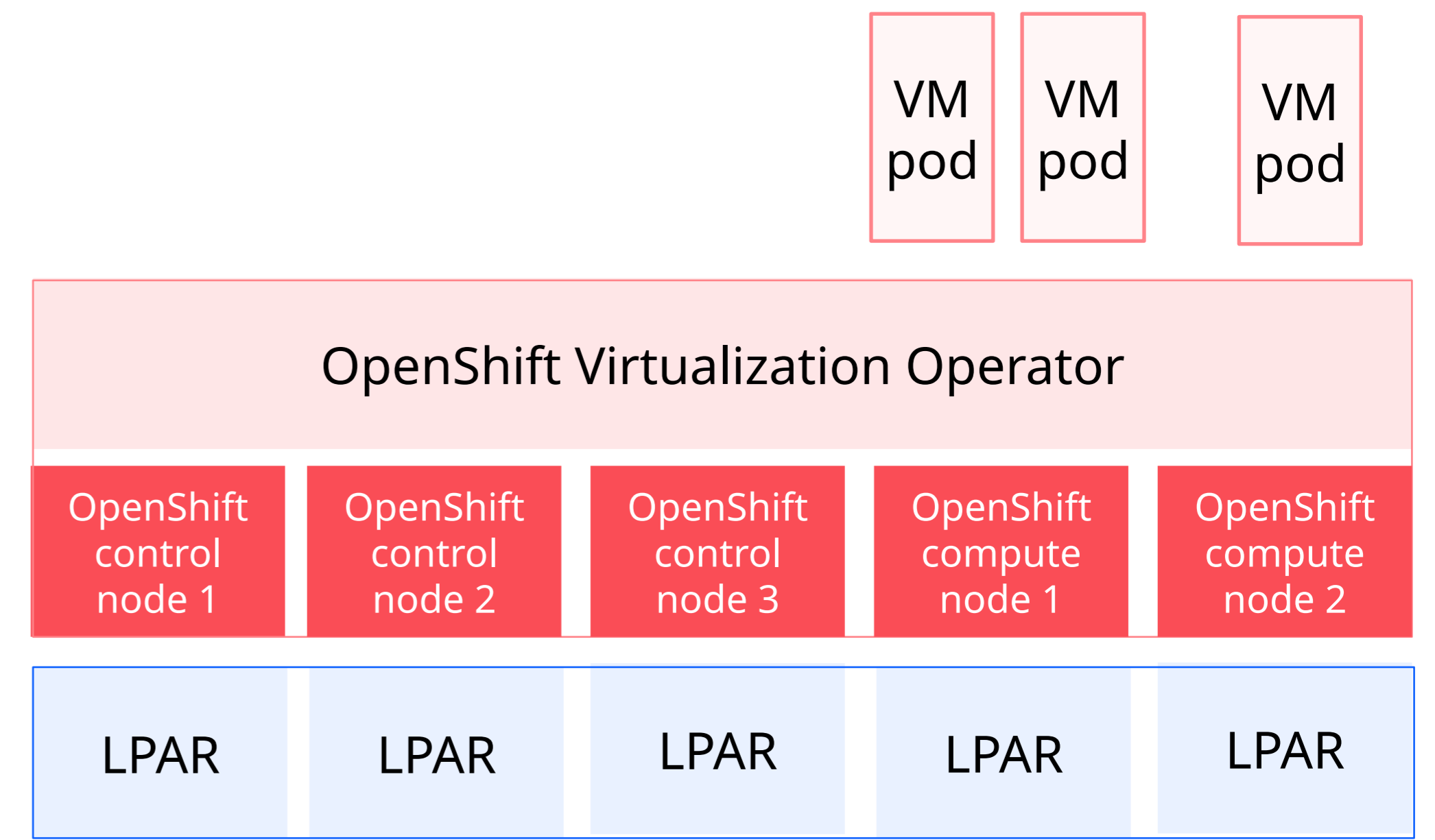

- Good for:
- High Availability
  - Further Scalability
  - Live Guest Migration\*\*

# Virtualization Development Focus Areas

# z/VM – Development Focus Areas

See Frederik Hartmann's presentation for details!

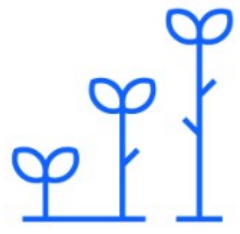

## Scalability

The capacity of a system to handle a growing amount of work or to utilize a growing number of resources.



## Usability

The extent to which a product can be used by specified users to achieve specified goals with effectiveness, efficiency and satisfaction



## Resiliency

The ability of a system to continue to operate under adverse conditions or stress, even if in a degraded or debilitated state, while maintaining essential operational capabilities.

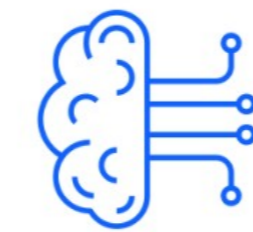

## Hardware Support

The capability of an operating system or application to fully utilize the hardware of the system it is being executed on.

# KVM – Development Focus Areas

- **KVM as Technology Base for Open Source Innovation**
  - Kata Containers → native Confidential Computing solution for containers
    - Delivered by Red Hat as OpenShift Sandboxed Containers
  - KubeVirt → converged management of containers and Vms
    - Delivered by Red Hat as OpenShift Virtualization
  - Flexibility and agility leveraging the Open Source community
- **Continued Performance Enhancements**
  - CPU management, including scheduling improvements
  - Memory management, including memory overcommit
  - I/O management, including PCI pass-through support
- **Exploitation of IBM Z Differentiating Capabilities**
  - Confidential Computing / Secure Execution enhancements
    - Secure Execution Attestation, Secure Dump, huge page support, Retrievable Secrets
  - Crypto support enhancements
    - Crypto Express passthrough, including hot plug/unplug and persistent configuraton

# Red Hat OpenShift Virtualization – Development Focus Areas

- **IBM Z differentiation**
  - Secure Execution (Tech Preview since 4.20; GA in 4.21; SE Live Guest Migration t.b.d.)
  - HW support: SMC-D operator, PCI passthrough, crypto (HSM) passthrough
  - GDPS support for OpenShift Virtualization
- **Cross-platform capabilities**
  - Hosted control plane support for IBM Z
  - Multi-architecture support for OpenShift Virtualization
- **Simplification**
  - Simplified OpenShift installation, in particular in LPAR
  - Mixed-mode OpenShift – add LPARs to z/VM (or KVM) based cluster
  - Operational enhancements to software-defined storage
- **Performance Enhancements**
  - Exploit recent and upcoming KVM improvements
  - Ongoing OpenShift base work (incl. SDS, SDN)

# OpenShift Virtualization

## Mixed platform cluster

Use case:

Extending an existing RHOCP cluster on z/VM (or KVM) with one or more compute nodes on LPARs and leveraging RHOCPV to create VMs on the new compute nodes

- Reusing existing clusters
- Saving LPARs by deploying control nodes on z/VM (or KVM) guests

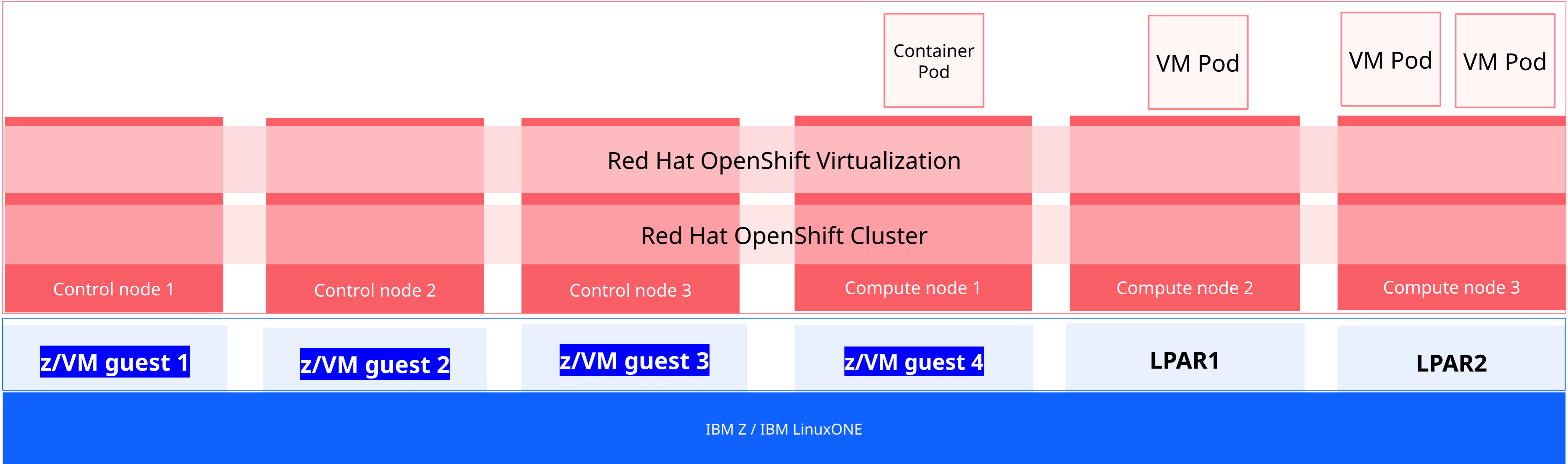

# Nested Red Hat OpenShift Cluster(s) with RHOCPV

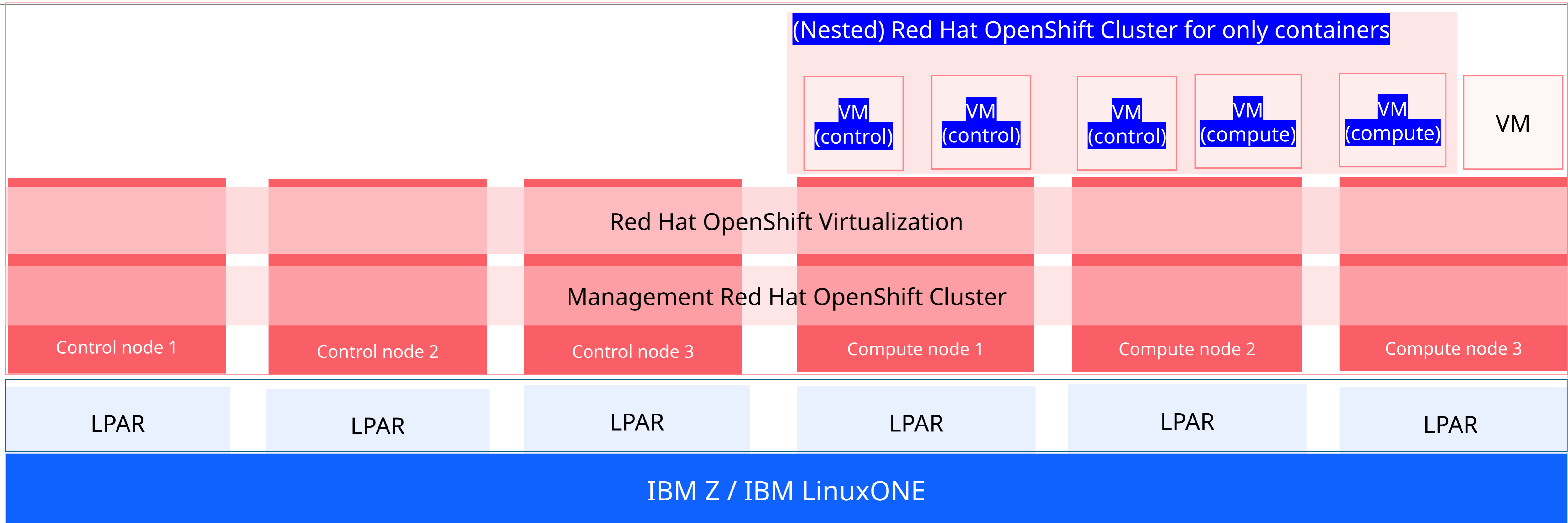

# Hosted Red Hat OpenShift Cluster(s) with RHOCPV and HCP

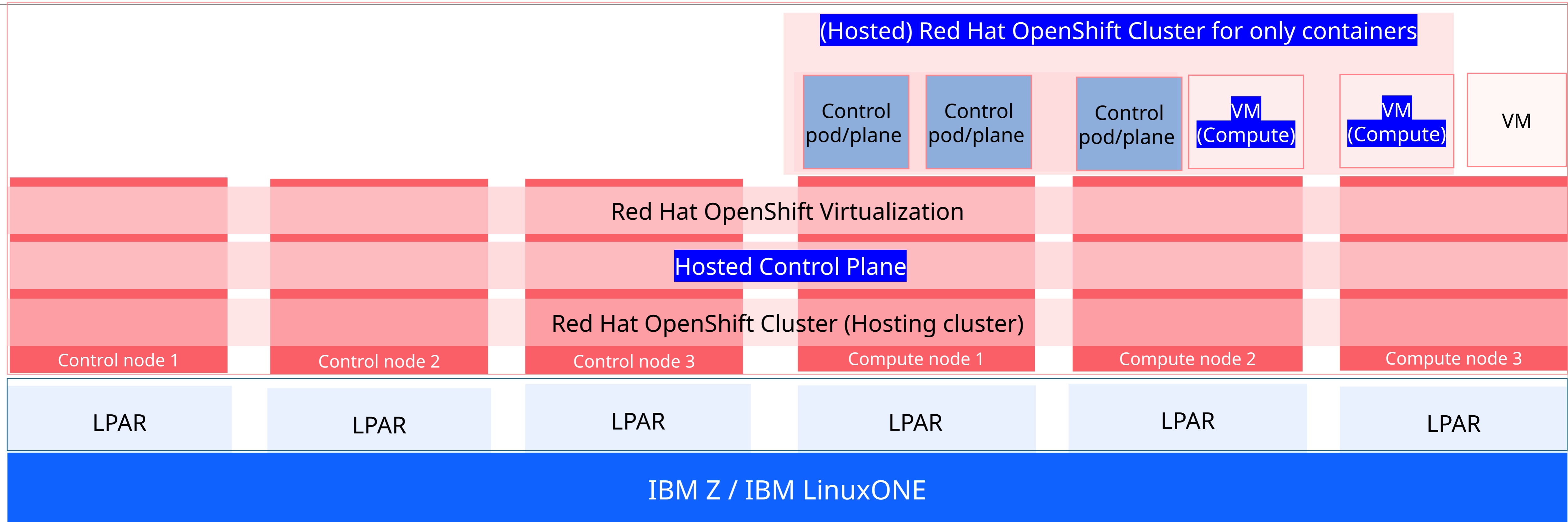

# OpenShift Virtualization

## For Confidential Computing workload

### OpenShift Virtualization :

- leverages IBM Secure Execution technology to enable you to run confidential computing workloads
- leverages built-in encryption of data in memory to prevent information access from operators, malicious admins, and privileged software

Simplifies exploitation on a solution platform layer by providing :

- **Ease of use** of the underlying technology
- **Automation** to build IBM Secure Execution images
- **Integration with CI/CD** frameworks (like OpenShift Pipelines) to automate build of SE Images and management of SE VMs

# OpenShift Virtualization 4.21

## Secure Execution - GA

Use case:

RHOCPV creating VMs in Secure Execution mode

- VM memory is protected against the host and the hypervisor as well as other VMs
- Data and the workload running inside the VM is protected by the firmware layer

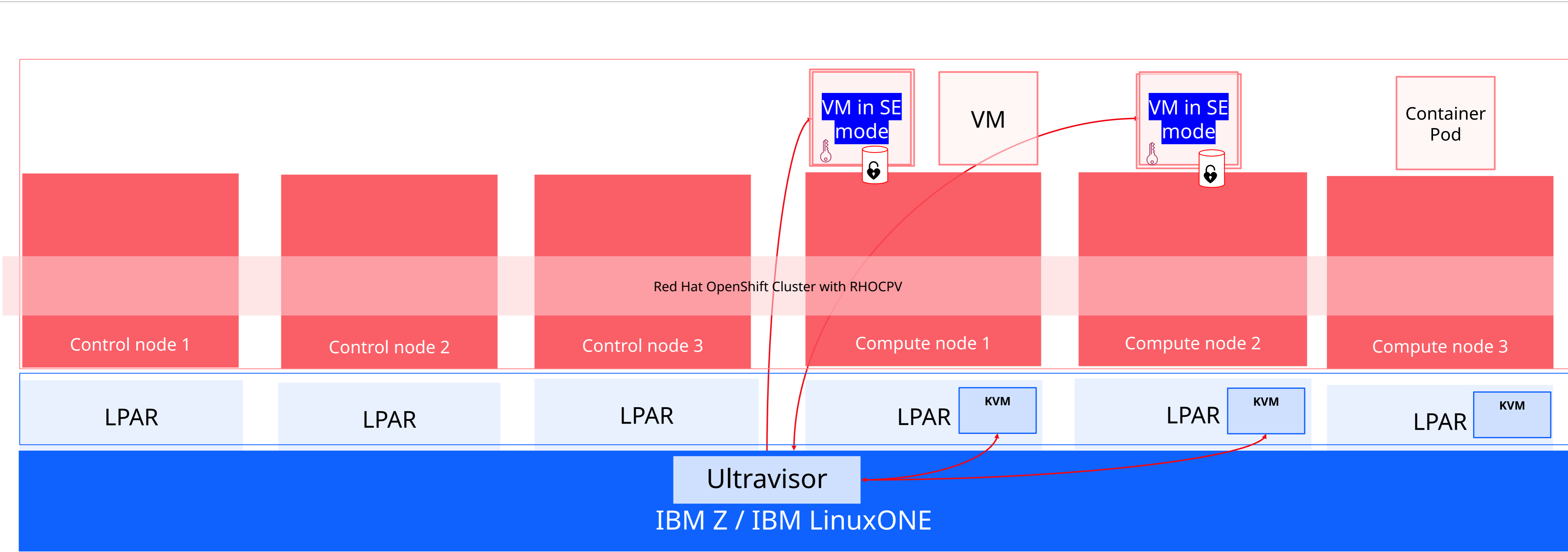

[https://docs.redhat.com/en/documentation/openshift\\_container\\_platform/4.20/html/virtualization/creating-a-virtual-machine#virt-configuring-ibm-secure-execution-vms-ibm-z](https://docs.redhat.com/en/documentation/openshift_container_platform/4.20/html/virtualization/creating-a-virtual-machine#virt-configuring-ibm-secure-execution-vms-ibm-z)



# Hypervisor Choices

# Your choice of the right hypervisor

## z/VM

- **Unique Features**

- Production **Oracle** workload environments
- Deploy Linux, **z/OS®**, **z/TPF** and **VSEn** on the same hypervisor
- Clustered administration of multiple z/VM instances via Single System Image (SSI)
- Proven **HA solutions** like GDPS readily available
- Integrated **security manager** available
- Simulate multi-machine HA setups for z/OS

- **Other considerations**

- Most complete virtualization on the platform
- Most sophisticated sharing and overcommitment of memory
- Substantial ISV ecosystem
- Synergies across multiple guest OS'
- Automation: IBM Cloud Infrastructure Center or vendor solutions
- Compliance: Security and Compliance Center
- Requires platform specific skills – training materials available

## OpenShift Virtualization

- **Unique Features**

- **Converged management** of containers and VMs
- Native **Confidential Computing** via Secure Execution
- No extra license **cost** - available as OpenShift feature
- **HA solution** via OpenShift capabilities
- **Live Guest Migration** of busy guests via KVM
- Integrate **multiple architectures** into cluster

- **Other considerations**

- Skills synergy with KVM on other HW platforms
- Skills readily available in the market
- Open source ecosystem
- Automation: via OpenShift capabilities
- Compliance: Security and Compliance Center

# Infrastructure Vision: Integration of z/VM, OpenShift Virtualization, zCX and Platform Management

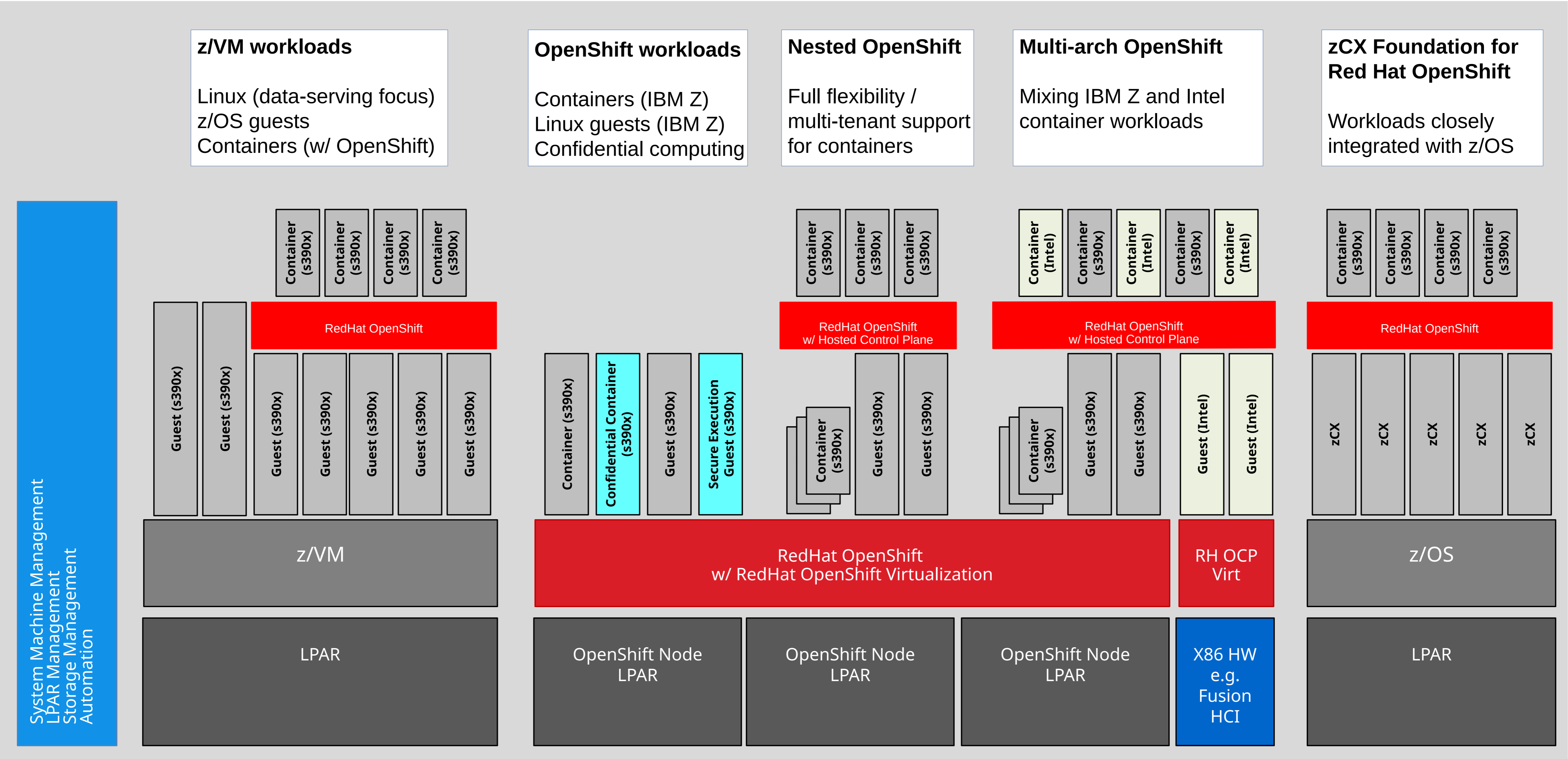

# Summary and Discussion

- **z/VM remains the premier hypervisor on the platform**
  - Ongoing investment in scalability, simplification, resiliency
  - Optimize for data-serving workloads
- **Red Hat OpenShift Virtualization on IBM Z offers a new alternative**
  - Based on proven KVM open-source hypervisor technology
  - Industry-standard platform integrating VMs and containers
- **Clients are free to choose their hypervisor solution**
  - Up to client preferences and available skills
  - IBM recommendations based on workload characteristics

